

NCL30059

High-Voltage Half-Bridge Controller for LED Lighting Applications

The NCL30059 is a self-oscillating high voltage MOSFET driver primarily tailored for LED driver applications using half-bridge topology. LLC and LCC configurations are supported with optimized wide range control offered by the latter for Constant Current (CC) applications. Due to its proprietary 600 V technology, the driver is useful for bulk voltages utilized in 277 VAC lighting applications. Operating frequency of the driver can be adjusted from 25 kHz to 250 kHz using a single resistor. Adjustable brown-out protection assures correct bulk voltage operating range. An internal 100 ms PFC delay timer ensures the converter is enabled after the bulk voltage is fully stabilized. The device provides fixed dead-time which helps to lower the shoot-through current.

Features

- Wide Operating Frequency Range – from 25 kHz to 250 kHz
- Minimum Frequency Adjust Accuracy $\pm 3\%$
- Fixed Dead Time – 0.6 μs
- Adjustable Brown-out Protection for a Simple PFC Association
- 100 ms PFC Delay Timer
- Latched Input for Severe Fault Conditions, e.g. Overtemperature or OVP
- Internal 16 V V_{CC} Clamp
- Low Startup Current of 50 μA Maximum
- 1 A / 0.5 A Peak Current Sink / Source Drive Capability
- Operation up to 600 V Bulk Voltage
- Internal Temperature Shutdown
- Supports Outdoor Use: -40°C to $+125^{\circ}\text{C}$
- PSR Current Regulation $\pm 2\%$
- Efficiency up to 92%
- SOIC-8 Package
- These are Pb-Free Devices

Typical Applications

- Low Cost Resonant Converters
- Low Parts Count
- CV and CC LED Drivers
- Wide Output Voltage Range LCC Drivers
- Wallpack and Bollard LED Drivers
- High Bay and Streetlight LED Drivers



ON Semiconductor®

www.onsemi.com

MARKING DIAGRAM

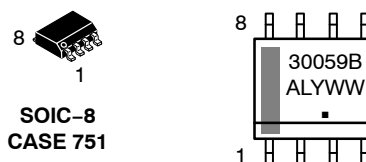

A = Assembly Location
L = Wafer Lot
Y = Year
WW = Work Week
▪ = Pb-Free Package

PINOUT DIAGRAM

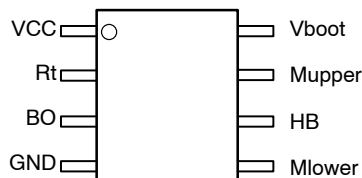

ORDERING INFORMATION

Device	Package	Shipping†
NCL30059BDR2G	SOIC-8 (Pb-Free)	2500 / Tape & Reel

†For information on tape and reel specifications, including part orientation and tape sizes, please refer to our Tape and Reel Packaging Specifications Brochure, BRD8011/D.

NCL30059

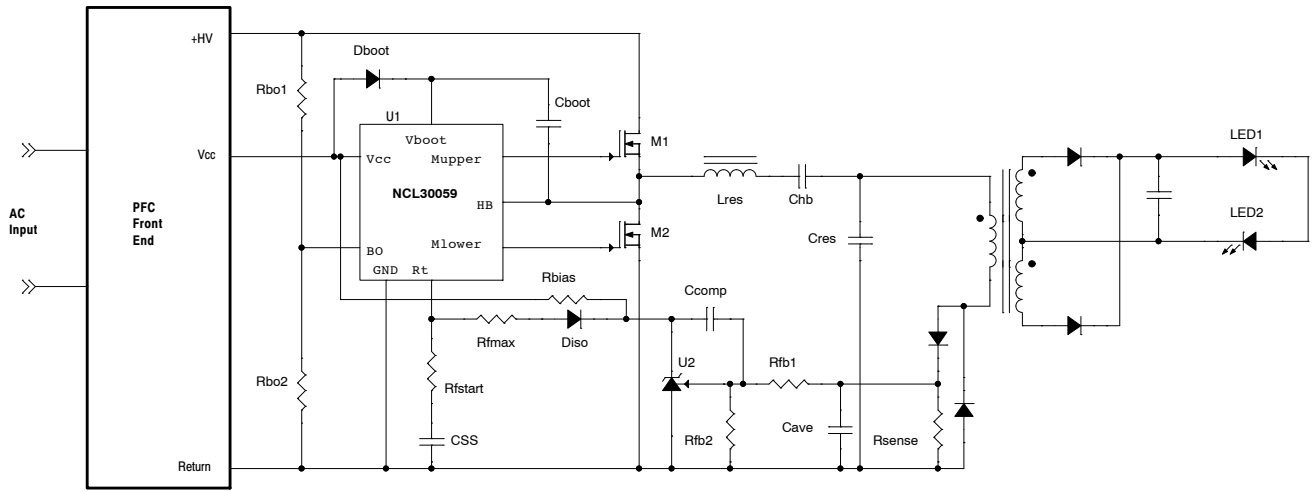

Figure 1. Typical LCC Application Example

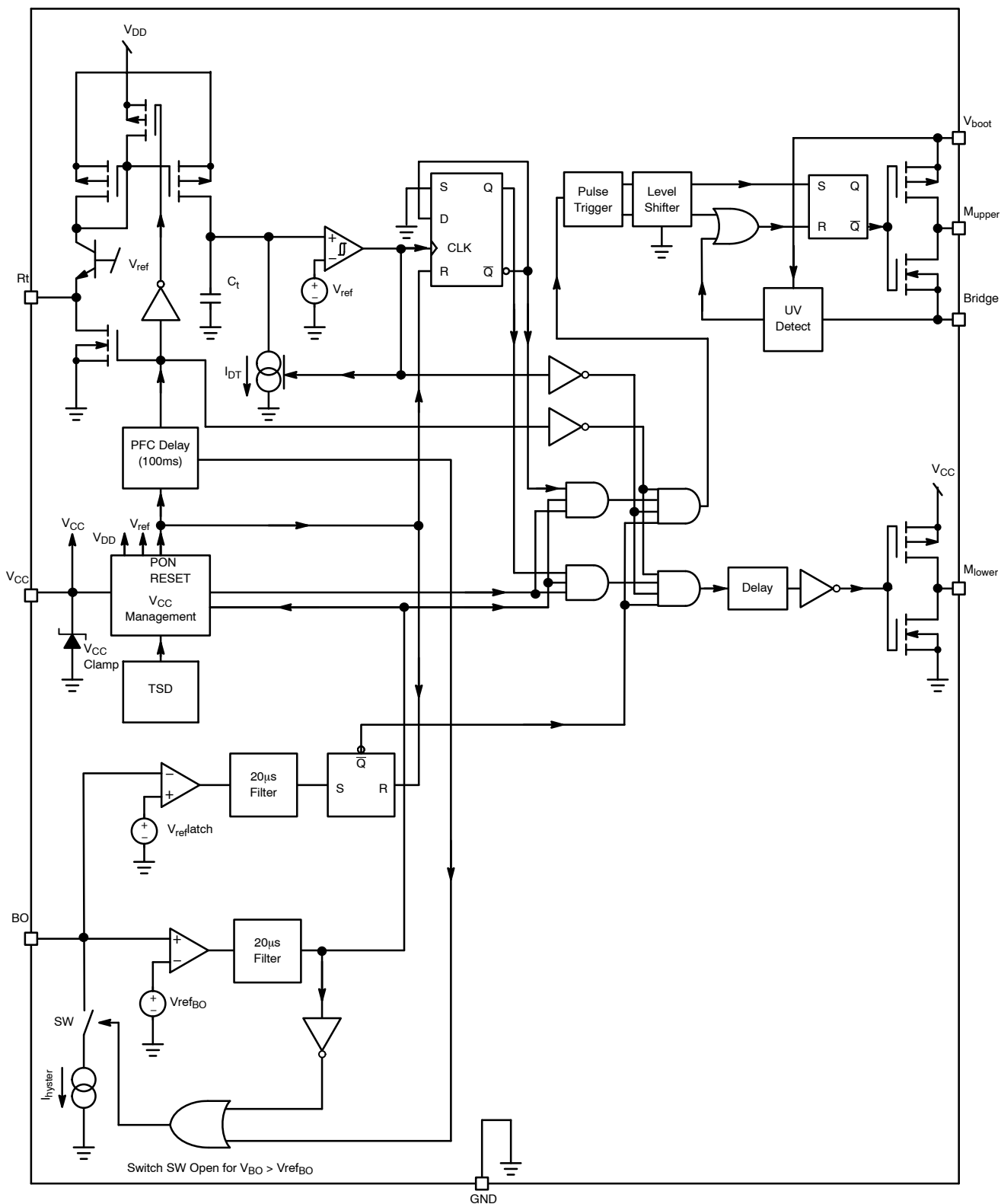

Figure 2. Internal Circuit Architecture

NCL30059

PIN FUNCTION DESCRIPTION

Pin #	Pin Name	Function	Pin Description
1	V _{CC}	Supplies the Driver	The driver accepts up to 16 V (given by internal zener clamp).
2	Rt	Timing Resistor	Connecting a resistor between this pin and GND, sets the operating frequency
3	BO	Brown-Out	Detects low input voltage conditions. When brought above V _{latch} , it fully latches off the driver.
4	GND	IC Ground	–
5	M _{lower}	Low-Side Driver Output	Drives the lower side MOSFET.
6	HB	Half-Bridge Connection	Connects to the half-bridge output.
7	M _{upper}	High-Side Driver Output	Drives the higher side MOSFET.
8	V _{boot}	Bootstrap Pin	The floating supply terminal for the upper stage.

MAXIMUM RATINGS TABLE

Symbol	Rating	Value	Unit
V _{bridge}	High Voltage Bridge Pin – Pin 6	–1 to +600	V
V _{boot} – V _{bridge}	Floating Supply Voltage	0 to 20	V
VDRV_HI	High-Side Output Voltage	V _{bridge} – 0.3 to V _{boot} + 0.3	V
VDRV_LO	Low-Side Output Voltage	–0.3 to V _{CC} + 0.3	V
dV _{bridge} /dt	Allowable Output Slew Rate	± 50	V/ns
I _{CC}	Maximum Current that Can Flow into V _{CC} Pin (Pin 1), (Note 1)	20	mA
V _{Rt}	Rt Pin Voltage	–0.3 to 5	V
	Maximum Voltage, All Pins (Except Pins 4 and 5)	–0.3 to 10	V
R _{θJA}	Thermal Resistance Junction-to-Air, IC Soldered on 50 mm ² Cooper 35 μm	178	°C/W
R _{θJA}	Thermal Resistance Junction-to-Air, IC Soldered on 200 mm ² Cooper 35 μm	147	°C/W
	Storage Temperature Range	–60 to +150	°C
	ESD Capability, Human Body Model (All Pins Except Pins 1, 6, 7 and 8)	2	kV
	ESD Capability, Machine Model (All Pins Except Pins 1, 6, 7 and 8)	200	V

Stresses exceeding those listed in the Maximum Ratings table may damage the device. If any of these limits are exceeded, device functionality should not be assumed, damage may occur and reliability may be affected.

1. This device contains internal zener clamp connected between V_{CC} and GND terminals. Current flowing into the V_{CC} pin has to be limited by an external resistor when device is supplied from supply which voltage is higher than V_{CCclamp} (16 V typically). The I_{CC} parameter is specified for VBO = 0 V.

NCL30059

ELECTRICAL CHARACTERISTICS (For typical values $T_J = 25^\circ\text{C}$, for min/max values $T_J = -40^\circ\text{C}$ to $+125^\circ\text{C}$, Max $T_J = 150^\circ\text{C}$, $V_{CC} = 12\text{ V}$, unless otherwise noted)

Characteristic	Pin	Symbol	Min	Typ	Max	Unit
----------------	-----	--------	-----	-----	-----	------

SUPPLY SECTION

Turn-On Threshold Level, V_{CC} Going Up	1	$V_{CC_{ON}}$	10	11	12	V
Minimum Operating Voltage after Turn-On	1	$V_{CC_{min}}$	8	9	10	V
Startup Voltage on the Floating Section	1	$V_{boot_{ON}}$	7.8	8.8	9.8	V
Cutoff Voltage on the Floating Section	1	$V_{boot_{min}}$	7	8	9	V
V_{CC} Level at which the Internal Logic gets Reset	1	$V_{CC_{reset}}$	-	6.5	-	V
Startup Current, $V_{CC} < V_{CC_{ON}}$, $0^\circ\text{C} \leq T_{amb} \leq +125^\circ\text{C}$	1	I_{CC}	-	-	50	μA
Startup Current, $V_{CC} < V_{CC_{ON}}$, $-40^\circ\text{C} \leq T_{amb} < 0^\circ\text{C}$	1	I_{CC}	-	-	65	μA
Internal IC Consumption, No Output Load on Pins 8/7 – 5/4, $F_{sw} = 100\text{ kHz}$	1	I_{CC1}	-	2.2	-	mA
Internal IC Consumption, 1 nF Output Load on Pins 8/7 – 5/4, $F_{sw} = 100\text{ kHz}$	1	I_{CC2}	-	3.4	-	mA
Consumption in Fault Mode (Drivers Disabled, $V_{CC} > V_{CC_{(min)}}$, $R_T = 3.5\text{ k}\Omega$)	1	I_{CC3}	-	2.56	-	mA
Consumption During PFC Delay Period, $0^\circ\text{C} \leq T_{amb} \leq +125^\circ\text{C}$		I_{CC4}	-	-	400	μA
Consumption During PFC Delay Period, $-40^\circ\text{C} \leq T_{amb} < 0^\circ\text{C}$		I_{CC4}	-	-	470	μA
Internal IC Consumption, No Output Load on Pin 8/7 $F_{WS} = 100\text{ kHz}$	8	I_{boot1}	-	0.3	-	mA
Internal IC Consumption, 1 nF Output Load on Pin 8/7 $F_{WS} = 100\text{ kHz}$	8	I_{boot2}	-	1.44	-	mA
Consumption in Fault Mode (Drivers Disabled, $V_{boot} > V_{boot_{min}}$)	8	I_{boot3}	-	0.1	-	mA
V_{CC} Zener Clamp Voltage @ 20 mA	1	$V_{CC_{clamp}}$	15.4	16	17.5	V

INTERNAL OSCILLATOR

Minimum Switching Frequency, $R_t = 35\text{ k}\Omega$ on Pin 2, $D_T = 600\text{ ns}$	2	$F_{SW\ min}$	24.25	25	25.75	kHz
Maximum Switching Frequency, $R_t = 3.5\text{ k}\Omega$ on Pin 2, $D_T = 600\text{ ns}$	2	$F_{SW\ max}$	208	245	282	kHz
Reference Voltage for all Current Generations	2	$V_{ref\ RT}$	3.33	3.5	3.67	V
Internal Resistance Discharging $C_{soft-start}$	2	$R_{t_{discharge}}$	-	500	-	Ω
Operating Duty Cycle Symmetry	5, 7	DC	48	50	52	%

NOTE: Maximum capacitance directly connected to Pin 2 must be under 100 pF.

DRIVE OUTPUT

Output Voltage Rise Time @ $CL = 1\text{ nF}$, 10–90% of Output Signal	5, 7	T_r	-	40	-	ns
Output Voltage Fall Time @ $CL = 1\text{ nF}$, 10–90% of Output Signal	5, 7	T_f	-	20	-	ns
Source Resistance	5, 7	R_{OH}	-	12	-	Ω
Sink Resistance	5, 7	R_{OL}	-	5	-	Ω
Dead-Time (Measured Between 50% of Rise and Fall Edge)	5,7	T_{dead}	540	610	720	ns
Leakage Current on High Voltage Pins to GND (600 Vdc)	6,7,8	IHV_Leak	-	-	5	μA

PROTECTION

Brown-Out Input Bias Current	3	$I_{BO_{bias}}$	-	0.01	-	μA
Brown-Out Level	3	V_{BO}	0.95	1	1.05	V
Hysteresis Current, $V_{pin3} < V_{BO}$	3	I_{BO}	15.6	18.2	20.7	μA
Latching Voltage on BO Pin	3	V_{latch}	1.9	2	2.1	V
Propagation Delay Before Drivers are Stopped	3	EN Delay	-	20	-	μs
Delay Before Any Driver Restart	-	PFC Delay	-	100	-	ms
Temperature Shutdown (Guaranteed by design)	-	TSD	140	-	-	$^\circ\text{C}$
Hysteresis	-	TSD _{hyste}	-	30	-	$^\circ\text{C}$

NCL30059

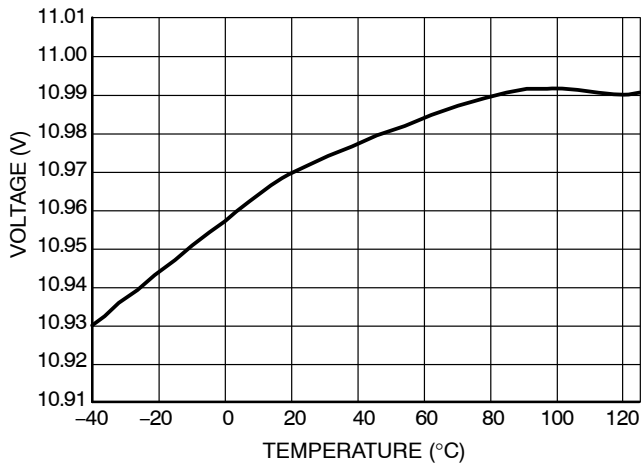

Figure 3. V_{CCon}

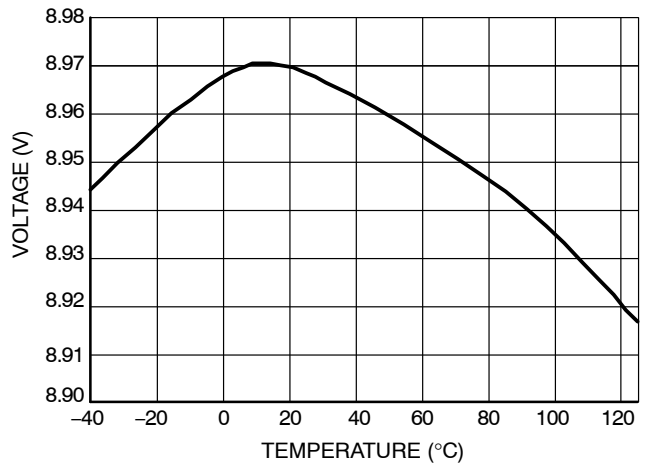

Figure 4. V_{CCmin}

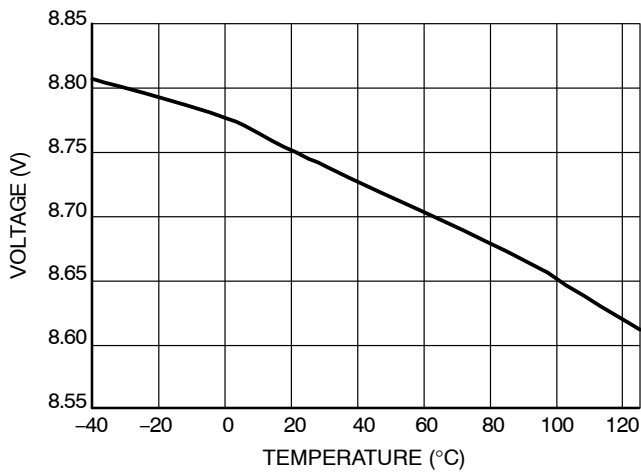

Figure 5. V_{BOOTon}

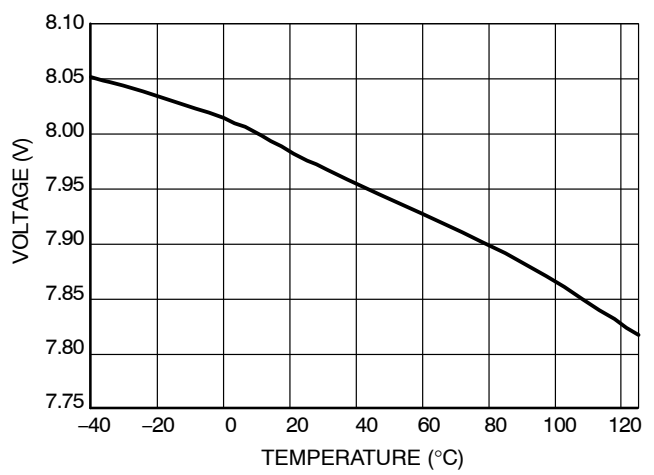

Figure 6. V_{BOOTmin}

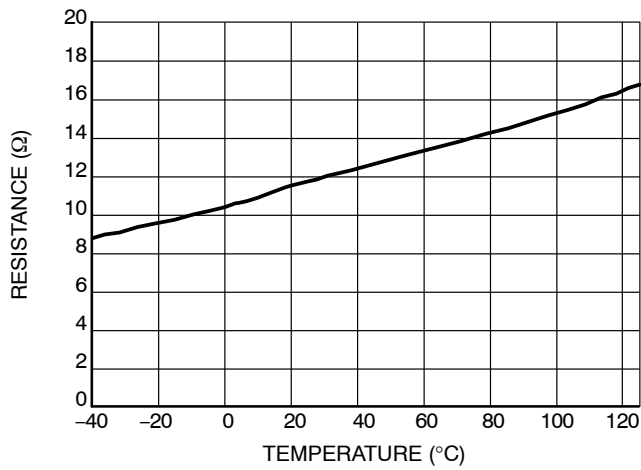

Figure 7. R_{OH}

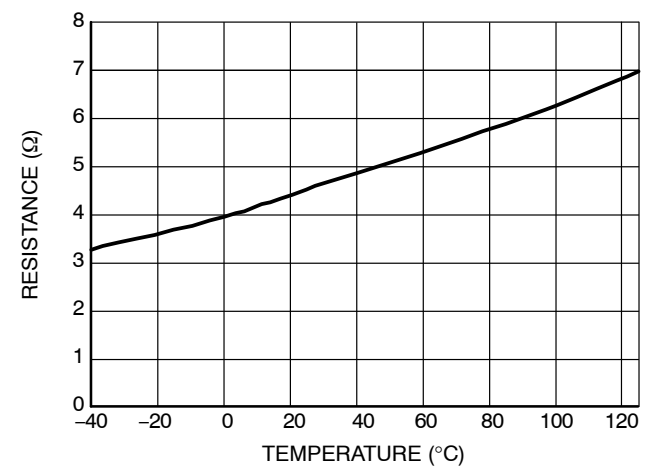

Figure 8. R_{OL}

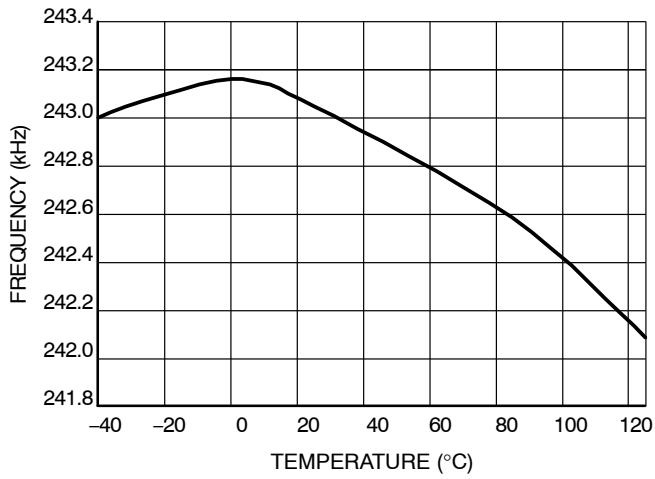

Figure 9. Fswmax

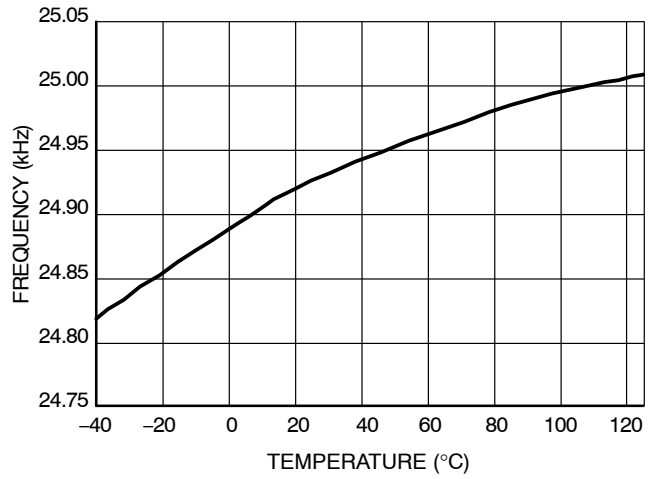

Figure 10. Fswmin

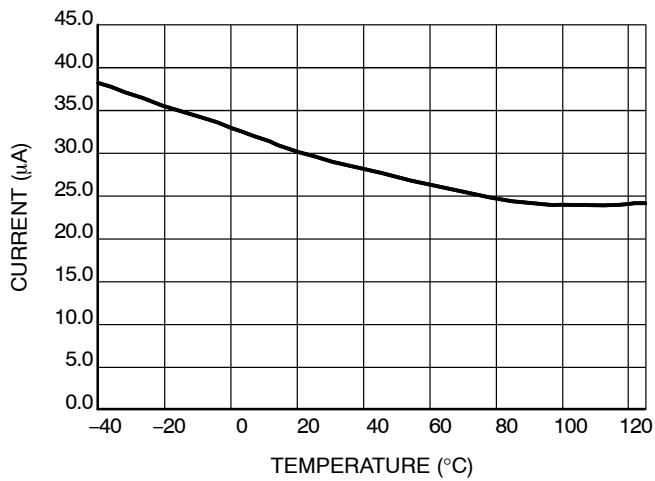

Figure 11. Icc_startup

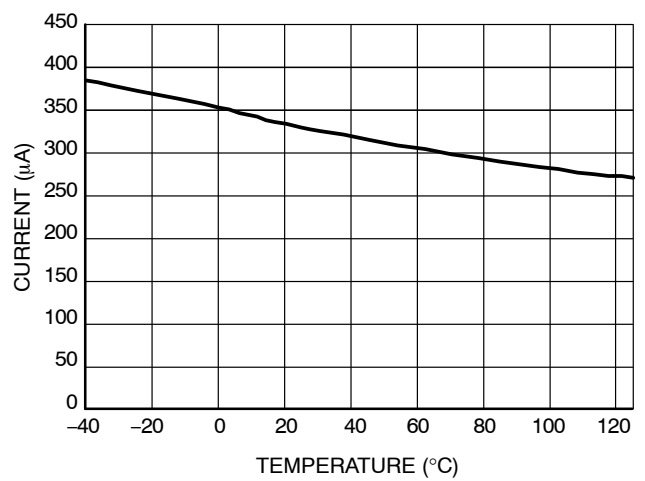

Figure 12. Icc4

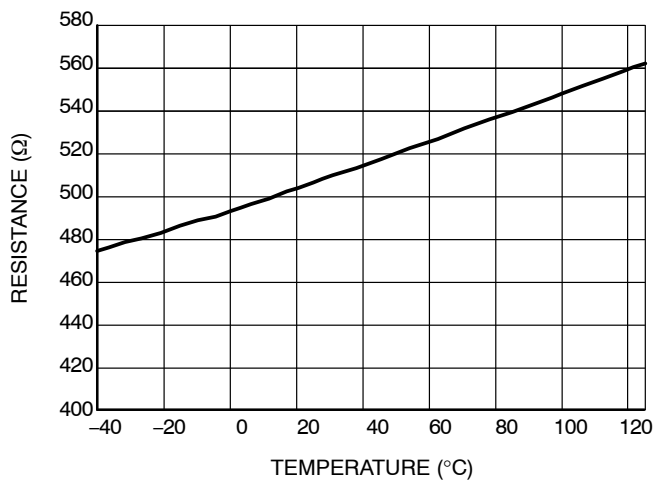

Figure 13. Rt_discharge

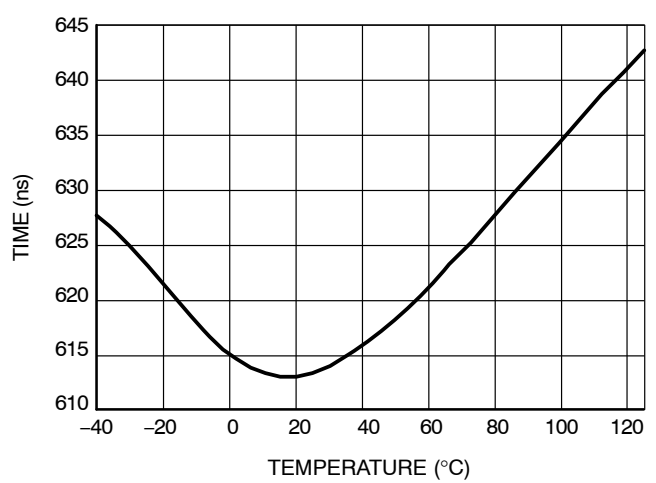

Figure 14. T_dead

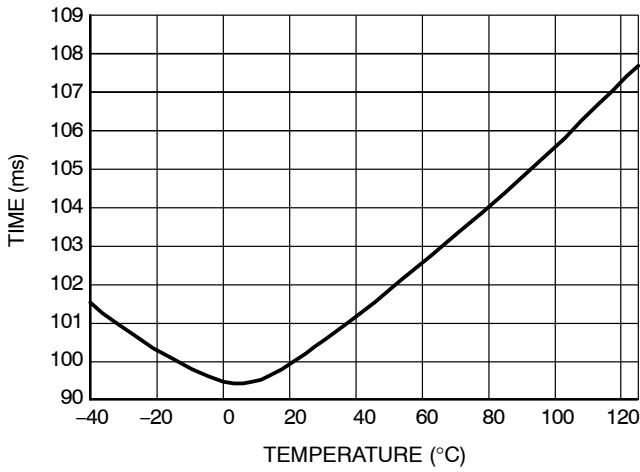

Figure 15. PFC_{delay}

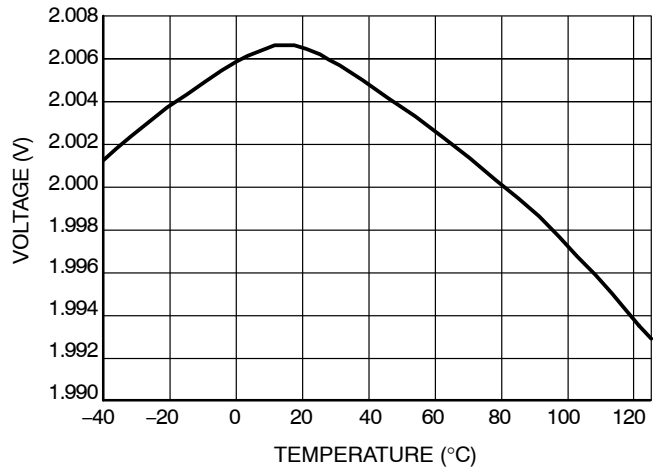

Figure 16. V_{LATCH}

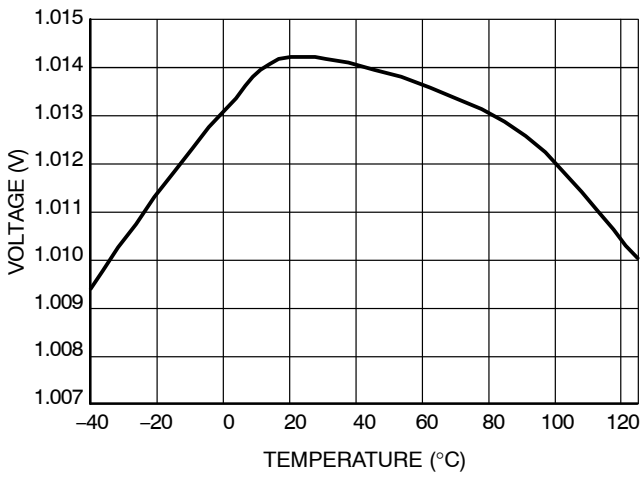

Figure 17. V_{BO}

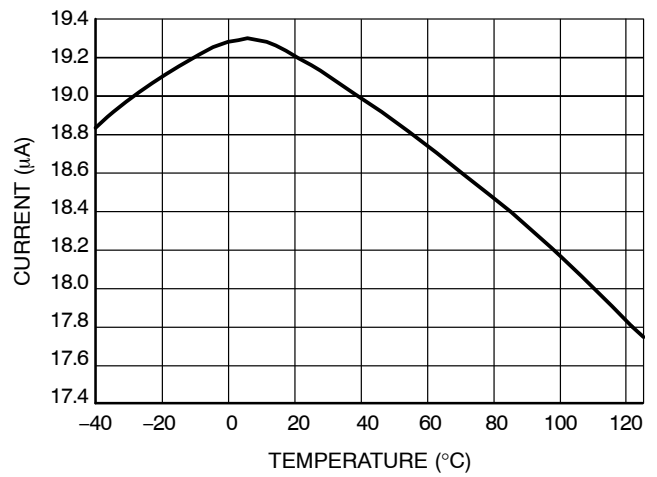

Figure 18. I_{BO}

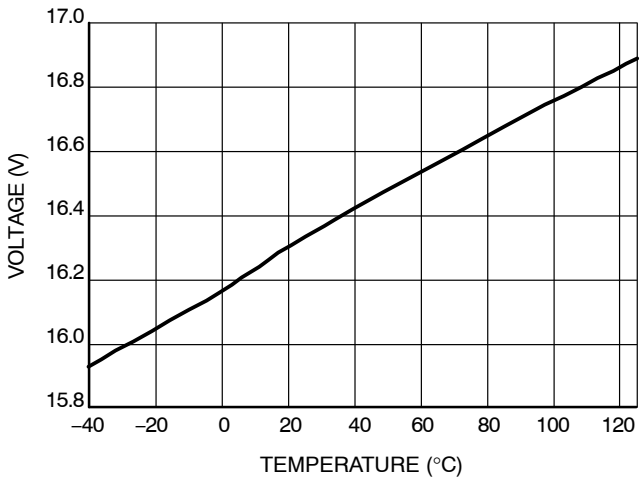

Figure 19. V_{CC_clamp}

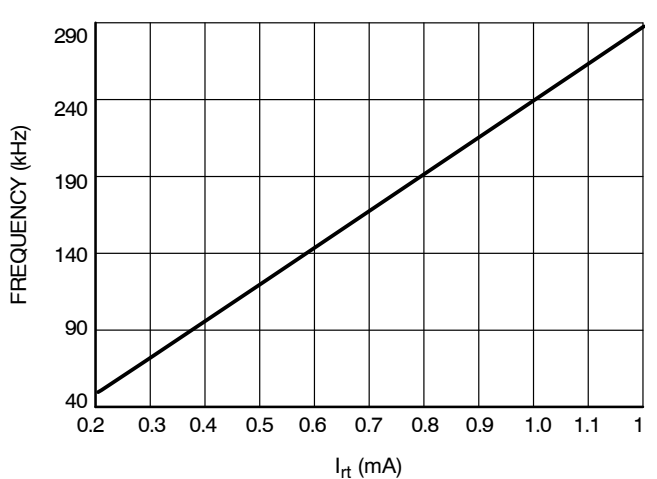

Figure 20. I_{rt} and Appropriate Frequency

APPLICATION INFORMATION

The NCL30059 is primarily intended to drive low cost half-bridge applications. It supports LLC and optimized LCC topologies offering wide output voltage range in constant current (CC) mode making it ideal for LED drivers. The IC includes several features that help the designer to cope with resonant SPMS design. All features are described thereafter:

- **Wide Operating Frequency Range:** The internal current controlled oscillator is capable to operate over wide frequency range up to 250 kHz. Minimum frequency accuracy is $\pm 3\%$.
- **Fixed Dead-Time:** Internal dead-time control is optimized to avoid cross conduction or shoot-through during transitions between low and high side conduction.
- **100 ms PFC Timer:** Fixed delay is placed to IC operation whenever the driver restarts ($V_{CC_{ON}}$ or BO_OK detect events). This delay assures that the bulk voltage will be stabilized prior to switching operation. Another benefit of this delay is that the soft start capacitor will be fully discharged before any restart.
- **Brown-Out Detection:** The BO input monitors bulk voltage level via resistor divider and thus assures that the application is working only for wanted bulk voltage band. The BO input sinks current of $18.2 \mu A$ until the $V_{ref_{BO}}$ threshold is reached. Designer can thus adjust the bulk voltage hysteresis according to the application needs.

- **Latched Input:** The latched comparator input is connected in parallel to the BO terminal to allow the designer latch the IC if necessary – overvoltage or overtemperature shutdown can be implemented using this latch. The supply voltage has to be cycled down below $V_{CC_{reset}}$ threshold, or V_{BO} diminished under V_{BO} level to reset the latch and enable restart.
- **Internal V_{CC} Clamp:** The internal zener clamp offers a way to prepare passive voltage regulator to maintain V_{CC} voltage at 16 V in case the controller is supplied from unregulated power supply or from bulk capacitor.
- **Low Startup Current:** This device features maximum startup current of $50 \mu A$ which allows the designer to use high value startup resistor for applications when driver is supplied from the auxiliary winding. Power dissipation of startup resistor is thus significantly reduced.

Current Controlled Oscillator

The current controlled oscillator features a high-speed circuitry allowing operation from 50 kHz up to 500 kHz. However, as a division by two internally creates the two Q and \bar{Q} outputs, the final effective signal on output Mlower and Mupper switches between 25 kHz and 250 kHz. The VCO is configured in such a way that if the current that flows out from the R_t pin increases, the switching frequency also goes up. Figure 21 shows the architecture of this oscillator.

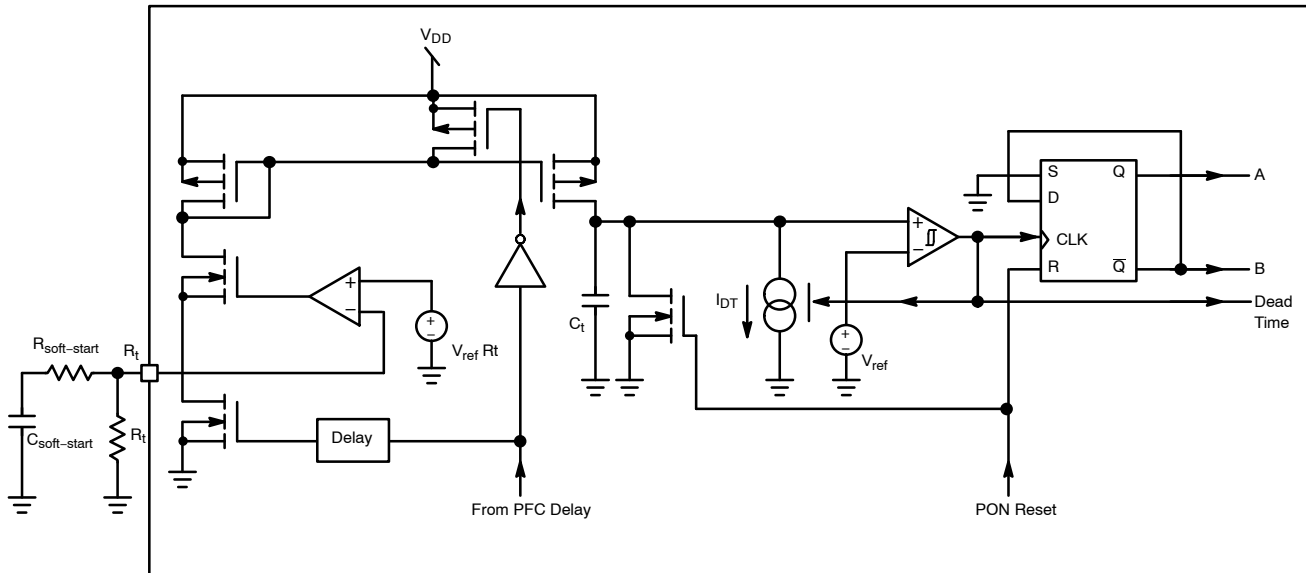

Figure 21. The Internal Current Controlled Oscillator Architecture

The internal timing capacitor C_t is charged by current which is proportional to the current flowing out from the R_t pin. The discharging current I_{DT} is applied when voltage on this capacitor reaches 2.5 V. The output drivers are disabled during discharge period so the dead time length is given by the discharge current sink capability. Discharge sink is disabled when voltage on the timing capacitor reaches zero and charging cycle starts again. The charging current and thus also whole oscillator is disabled during the PFC delay period to keep the IC consumption below 400 μ A.

This is valuable for applications that are supplied from auxiliary winding and V_{CC} capacitor is supposed to provide energy during PFC delay period.

For resonant LED driver applications it is necessary to adjust minimum operating frequency with high accuracy. The designer also needs to limit maximum operating and startup frequency. All these parameters can be adjusted using few external components connected to the R_t pin as depicted in Figure 22.

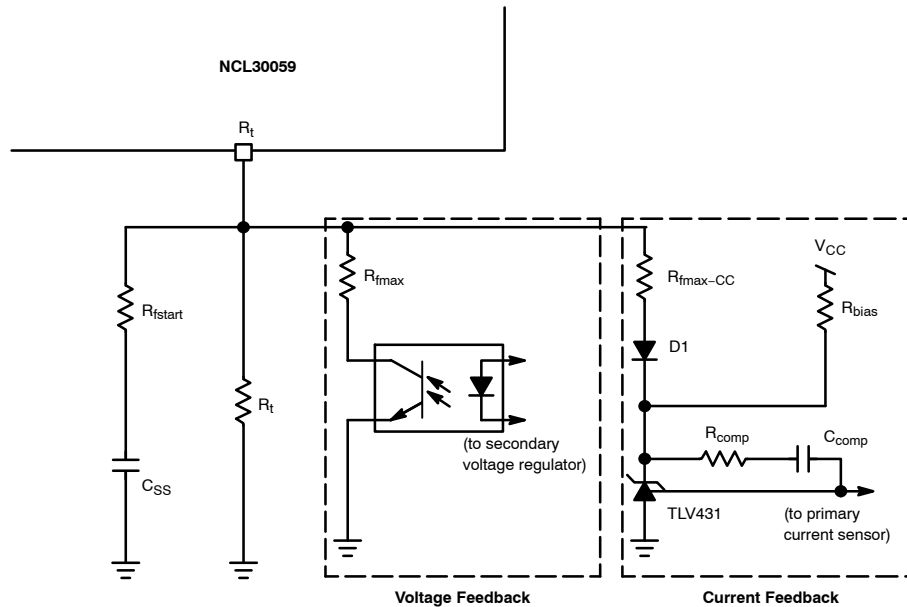

Figure 22. Typical R_t Pin Connection

The minimum switching frequency is given by the R_t resistor value. This frequency is reached if there is no optocoupler or current feedback action and soft start period has been already finished. The maximum switching frequency excursion is limited by the R_{fmax} selection. Note that the F_{max} value is influenced by the optocoupler saturation voltage value. Resistor R_{fstart} together with capacitor C_{SS} prepares the soft start period after PFC timer elapses. The R_t pin is grounded via an internal switch during the PFC delay period to assure that the soft start capacitor will be fully discharged via R_{fstart} resistor.

Constant LED current is achieved using a feedback loop monitoring the primary current. The sensing voltage must be scaled by the turns ratio of the transformer. The R_t pin reference voltage is $V_{refRt} = 3.5$ V. The control regulator operates on the difference between the R_t pin reference voltage and the minimum voltage compliance of the

regulator. This voltage difference is applied across $R_{fmax-CC}$.

The TLV431 shunt regulator is used in Figure 22 as the constant current control regulator. Diode $D1$ is used to establish minimum regulator bias current via resistor R_{bias} . Total saturation voltage of this solution is $1.25 + 0.6 = 1.85$ V for room temperature. Schottky diode will further decrease saturation voltage. The $R_{fmax-CC}$ resistor limits the maximum frequency delivered by this regulation loop. This parameter is affected by $D1$ temperature drift.

Brown-Out Protection

The Brown-Out circuitry (BO) offers a way to protect the application from low DC input voltages. Operation is blocked below a set threshold. Hysteresis is provided by the switched current source providing stable operation. The internal circuitry, depicted by Figure 23, offers a way to monitor the high-voltage (HV) rail.

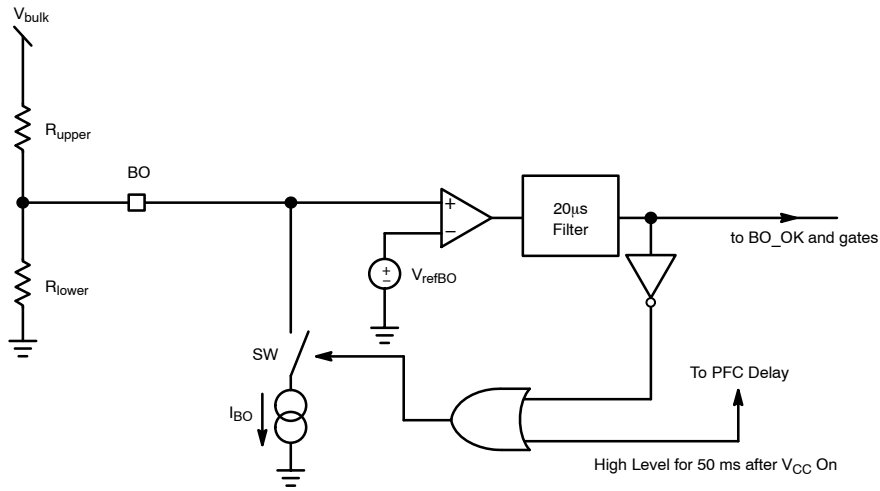

Figure 23. The internal Brown-Out Configuration with an Offset Current Sink

A resistive divider made of R_{upper} and R_{lower} brings a portion of the HV rail on Pin 3. Below the turn-on level, the $18.2 \mu\text{A}$ current sink (I_{BO}) is on. Therefore, the turn-on level is higher than the level given by the division ratio brought by the resistive divider. To the contrary, when the

internal BO_OK signal is high (PFC timer runs or Mlower and Mupper pulse), the I_{BO} sink is deactivated. As a result, it becomes possible to select the turn-on and turn-off levels via a few lines of algebra:

I_{BO} is ON

$$V_{ref_{BO}} = V_{bulk1} \cdot \frac{R_{lower}}{R_{lower} + R_{upper}} - I_{BO} \cdot \left(\frac{R_{lower} \cdot R_{upper}}{R_{lower} + R_{upper}} \right) \quad (\text{eq. 1})$$

I_{BO} is OFF

$$V_{ref_{BO}} = V_{bulk2} \cdot \frac{R_{lower}}{R_{lower} + R_{upper}} \quad (\text{eq. 2})$$

We can extract R_{lower} from Equation 2 and plug it into Equation 1, then solve for R_{upper} :

$$R_{lower} = V_{ref_{BO}} \cdot \frac{V_{bulk1} - V_{bulk2}}{I_{BO} \cdot (V_{bulk2} - V_{ref_{BO}})} \quad (\text{eq. 3})$$

$$R_{upper} = R_{lower} \cdot \frac{V_{bulk2} - V_{ref_{BO}}}{V_{ref_{BO}}} \quad (\text{eq. 4})$$

If we decide to turn-on our converter for V_{bulk1} equals 350 V and turn it off for V_{bulk2} equals 250 V, then for $I_{BO} = 18.2 \mu\text{A}$ and $V_{ref_{BO}} = 1.0 \text{ V}$ we obtain:

$$R_{upper} = 5.494 \text{ M}\Omega$$

$$R_{lower} = 22.066 \text{ V}$$

The bridge power dissipation is $400^2 / 5.517 \text{ M}\Omega = 29 \text{ mW}$ when front-end PFC stage delivers 400 V. Figure 24 simulation result confirms our calculations.

NCL30059

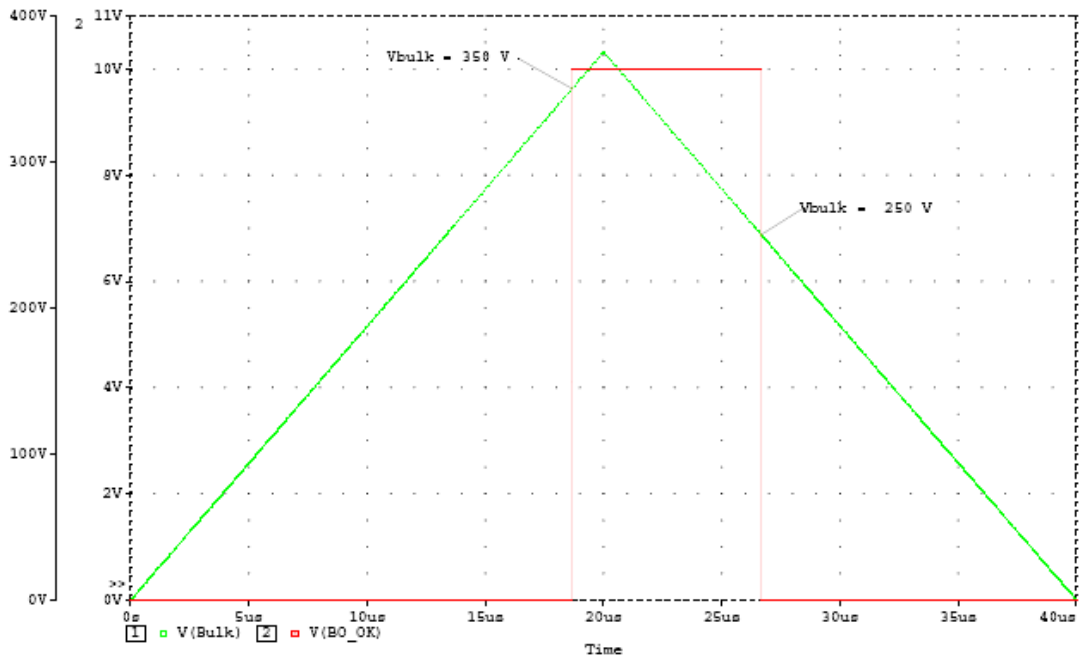

Figure 24. Simulation Results for 350/250 ON/OFF Brown-Out Levels

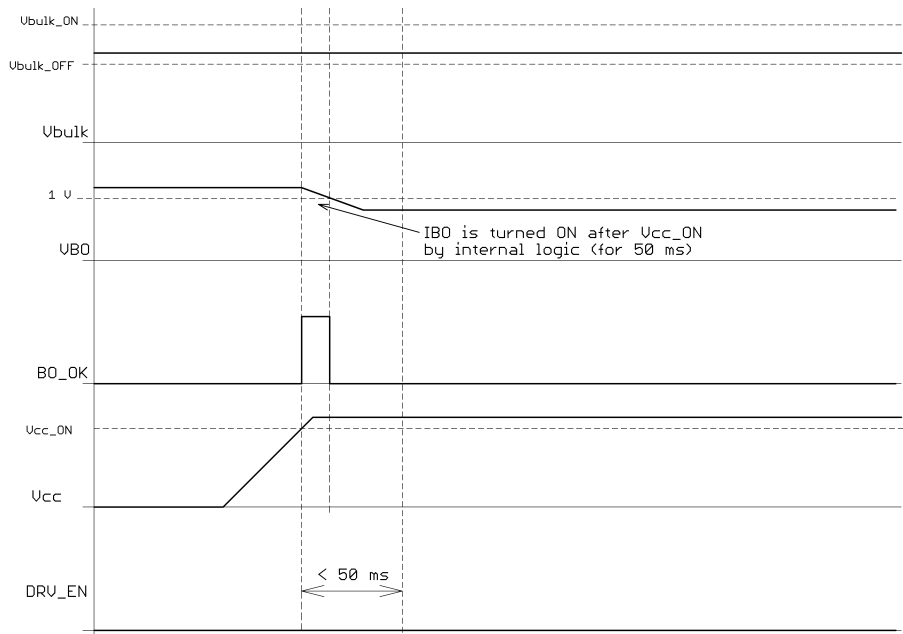

Figure 25. BO Input Functionality – $V_{bulk2} < V_{bulk} < V_{bulk1}$

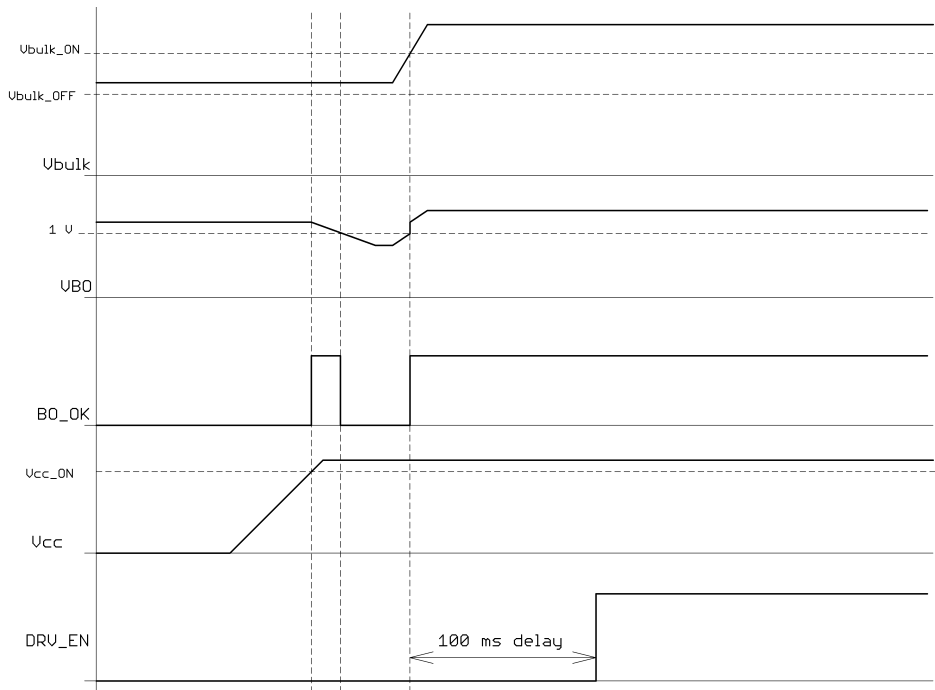

Figure 26. BO Input Functionality – $V_{bulk2} < V_{bulk} < V_{bulk1}$, PFC Start Follows

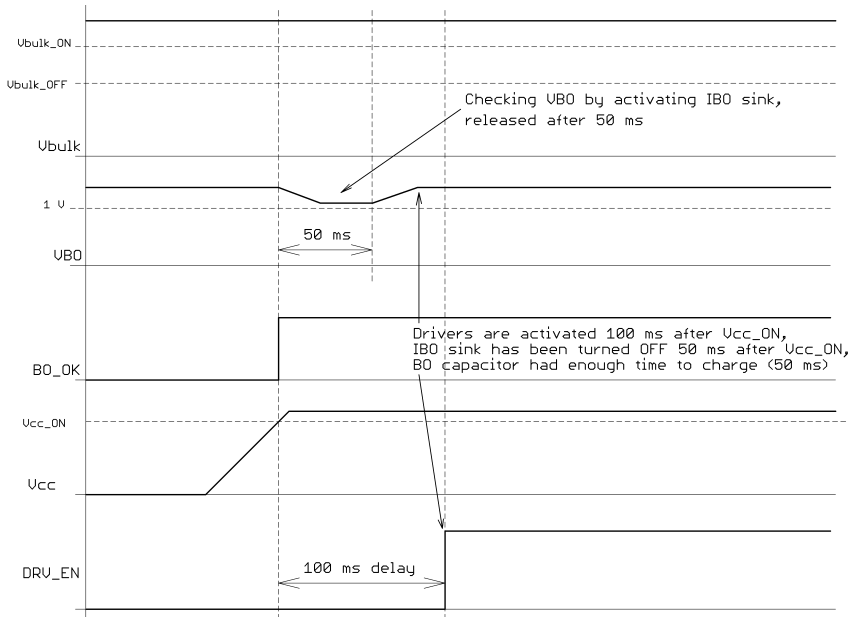

Figure 27. BO Input Functionality – $V_{bulk} > V_{bulk1}$

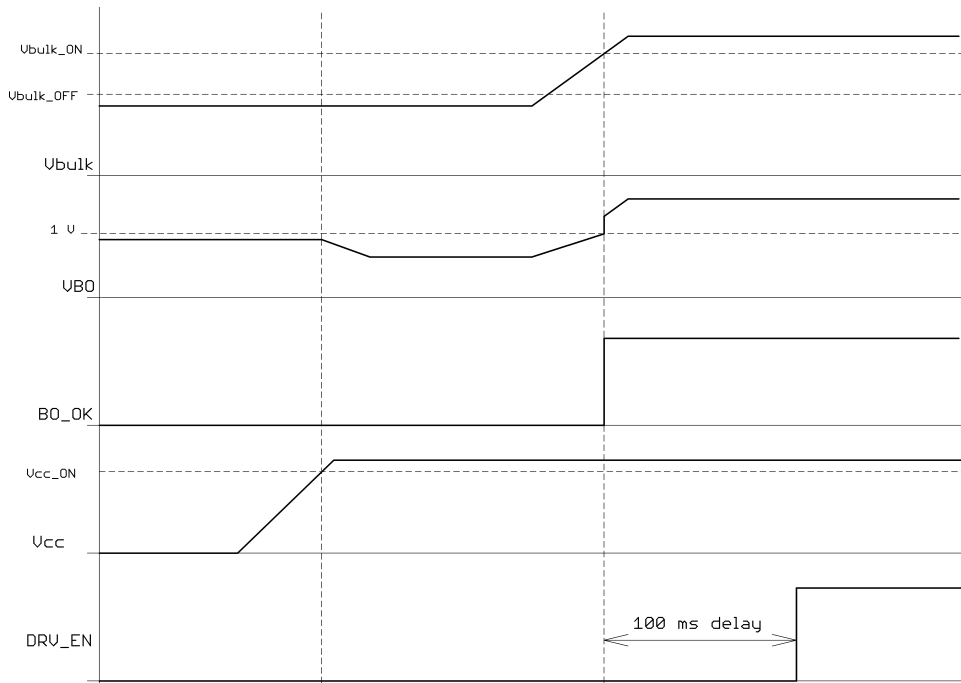

Figure 28. BO Input Functionality – $V_{bulk} < V_{bulk2}$, PFC Start Follows

The I_{BO} current sink is turned ON for 50 ms after any controller restart to let the BO input voltage stabilize (there can be connected big capacitor to the BO input and the I_{BO} is only 18.2 μA so it will take some time to discharge). Once the 50 ms one shoot pulse ends the BO comparator is supposed to either hold the I_{BO} sink turned ON (if the bulk voltage level is not sufficient) or let it turned OFF (if the bulk voltage is higher than V_{bulk1}). See Figures 25 through 28 for better understanding on how the BO input works.

Latched-Off Protection

There are some situations where the converter shall be fully turned-off and stay latched. This can happen in presence of an overvoltage (the feedback loop is drifting) or when an overtemperature is detected. Due to the addition of a comparator on the BO Pin, a simple external circuit can lift up this pin above V_{latch} (2 V typical) and permanently disable pulses. The V_{CC} needs to be cycled down below 6.5 V typically to reset the controller.

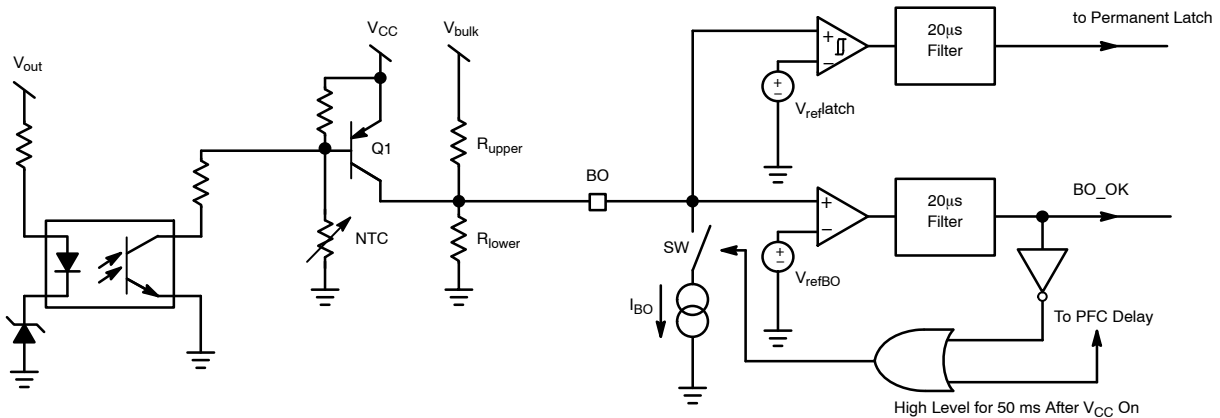

Figure 29. Adding a Comparator on the BO Pin Offers a Way to Latch-Off the Controller

On Figure 29, Q1 is biased off and does not affect the BO measurement as long as the NTC and the optocoupler are not activated. As soon as the secondary optocoupler senses an

OVP condition, or the NTC reacts to a high ambient temperature, Q1 base is biased on and the BO Pin goes up, permanently latching off the controller.

The High-Voltage Driver

Figure 30 shows the internal architecture of the high-voltage section. The device incorporates an upper UVLO circuitry that makes sure enough V_{gs} is available for

the upper side MOSFET. The V_{CC} for floating driver section is provided by C_{boot} capacitor that is refilled by external bootstrap diode.

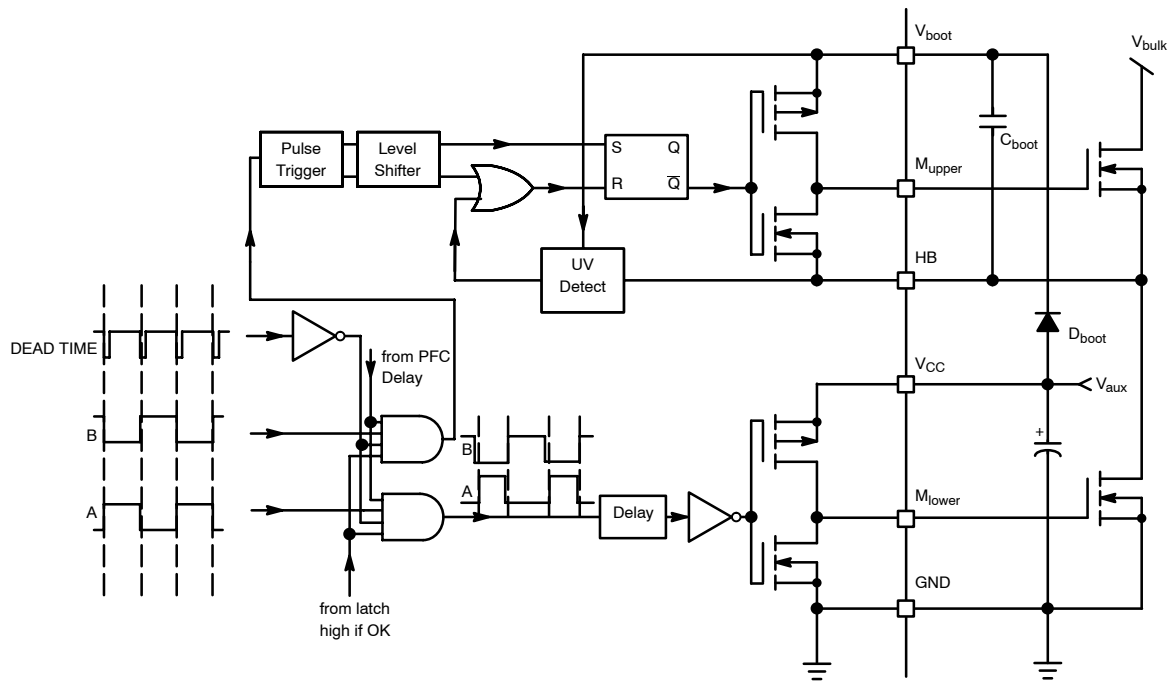

Figure 30. The Internal High-Voltage Section of the NCL30059

The A and B outputs are delivered by the internal logic, as depicted in block diagram. This logic is constructed in such a way that the M_{lower} driver starts to pulse first after any driver restart. The bootstrap capacitor is thus charged during first pulse. A delay is inserted in the lower rail to ensure good

matching between these propagating signals. As stated in the maximum rating section, the floating portion can go up to 600 Vdc and makes the IC perfectly suitable for offline applications featuring a 400 V PFC front-end stage.

MECHANICAL CASE OUTLINE PACKAGE DIMENSIONS

ON Semiconductor®

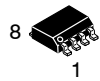

SCALE 1:1

SOIC-8 NB
CASE 751-07
ISSUE AK

DATE 16 FEB 2011

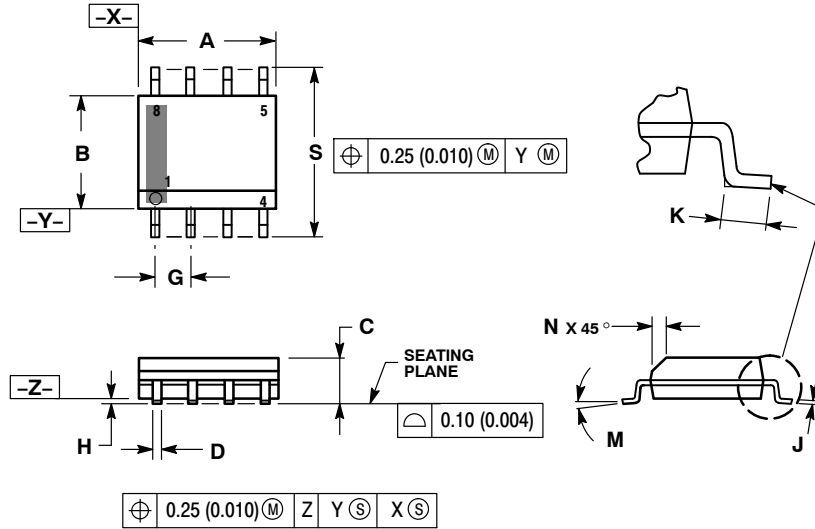

- NOTES:
1. DIMENSIONING AND TOLERANCING PER ANSI Y14.5M, 1982.
 2. CONTROLLING DIMENSION: MILLIMETER.
 3. DIMENSION A AND B DO NOT INCLUDE MOLD PROTRUSION.
 4. MAXIMUM MOLD PROTRUSION 0.15 (0.006) PER SIDE.
 5. DIMENSION D DOES NOT INCLUDE DAMBAR PROTRUSION. ALLOWABLE DAMBAR PROTRUSION SHALL BE 0.127 (0.005) TOTAL IN EXCESS OF THE D DIMENSION AT MAXIMUM MATERIAL CONDITION.
 6. 751-01 THRU 751-06 ARE OBSOLETE. NEW STANDARD IS 751-07.

DIM	MILLIMETERS		INCHES	
	MIN	MAX	MIN	MAX
A	4.80	5.00	0.189	0.197
B	3.80	4.00	0.150	0.157
C	1.35	1.75	0.053	0.069
D	0.33	0.51	0.013	0.020
G	1.27 BSC		0.050 BSC	
H	0.10	0.25	0.004	0.010
J	0.19	0.25	0.007	0.010
K	0.40	1.27	0.016	0.050
M	0°	8°	0°	8°
N	0.25	0.50	0.010	0.020
S	5.80	6.20	0.228	0.244

SOLDERING FOOTPRINT*

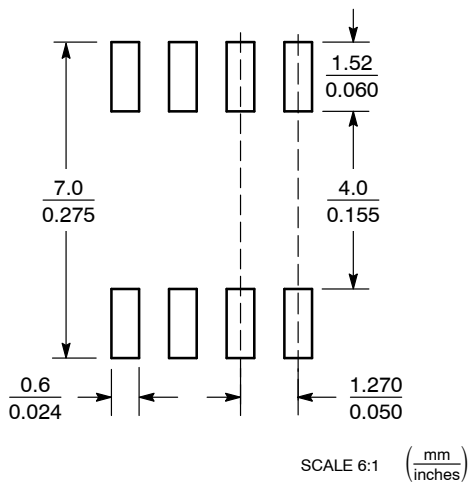

*For additional information on our Pb-Free strategy and soldering details, please download the ON Semiconductor Soldering and Mounting Techniques Reference Manual, SOLDERRM/D.

GENERIC MARKING DIAGRAM*

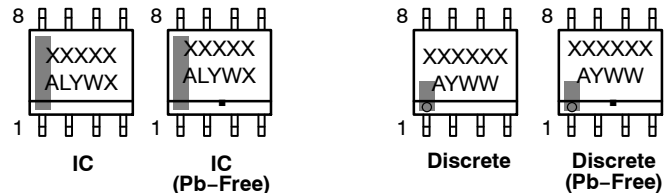

XXXXXX = Specific Device Code
 A = Assembly Location
 L = Wafer Lot
 Y = Year
 W = Work Week
 ■ = Pb-Free Package

XXXXXX = Specific Device Code
 A = Assembly Location
 Y = Year
 WW = Work Week
 ■ = Pb-Free Package

*This information is generic. Please refer to device data sheet for actual part marking. Pb-Free indicator, "G" or microdot "•", may or may not be present. Some products may not follow the Generic Marking.

STYLES ON PAGE 2

DOCUMENT NUMBER:	98ASB42564B	Electronic versions are uncontrolled except when accessed directly from the Document Repository. Printed versions are uncontrolled except when stamped "CONTROLLED COPY" in red.
DESCRIPTION:	SOIC-8 NB	PAGE 1 OF 2

ON Semiconductor and ON are trademarks of Semiconductor Components Industries, LLC dba ON Semiconductor or its subsidiaries in the United States and/or other countries. ON Semiconductor reserves the right to make changes without further notice to any products herein. ON Semiconductor makes no warranty, representation or guarantee regarding the suitability of its products for any particular purpose, nor does ON Semiconductor assume any liability arising out of the application or use of any product or circuit, and specifically disclaims any and all liability, including without limitation special, consequential or incidental damages. ON Semiconductor does not convey any license under its patent rights nor the rights of others.

SOIC-8 NB
CASE 751-07
ISSUE AK

DATE 16 FEB 2011

- | | | | |
|--|---|---|---|
| <p>STYLE 1:
 PIN 1. EMITTER
 2. COLLECTOR
 3. COLLECTOR
 4. EMITTER
 5. EMITTER
 6. BASE
 7. BASE
 8. EMITTER</p> | <p>STYLE 2:
 PIN 1. COLLECTOR, DIE, #1
 2. COLLECTOR, #1
 3. COLLECTOR, #2
 4. COLLECTOR, #2
 5. BASE, #2
 6. EMITTER, #2
 7. BASE, #1
 8. EMITTER, #1</p> | <p>STYLE 3:
 PIN 1. DRAIN, DIE #1
 2. DRAIN, #1
 3. DRAIN, #2
 4. DRAIN, #2
 5. GATE, #2
 6. SOURCE, #2
 7. GATE, #1
 8. SOURCE, #1</p> | <p>STYLE 4:
 PIN 1. ANODE
 2. ANODE
 3. ANODE
 4. ANODE
 5. ANODE
 6. ANODE
 7. ANODE
 8. COMMON CATHODE</p> |
| <p>STYLE 5:
 PIN 1. DRAIN
 2. DRAIN
 3. DRAIN
 4. DRAIN
 5. GATE
 6. GATE
 7. SOURCE
 8. SOURCE</p> | <p>STYLE 6:
 PIN 1. SOURCE
 2. DRAIN
 3. DRAIN
 4. SOURCE
 5. SOURCE
 6. GATE
 7. GATE
 8. SOURCE</p> | <p>STYLE 7:
 PIN 1. INPUT
 2. EXTERNAL BYPASS
 3. THIRD STAGE SOURCE
 4. GROUND
 5. DRAIN
 6. GATE 3
 7. SECOND STAGE Vd
 8. FIRST STAGE Vd</p> | <p>STYLE 8:
 PIN 1. COLLECTOR, DIE #1
 2. BASE, #1
 3. BASE, #2
 4. COLLECTOR, #2
 5. COLLECTOR, #2
 6. EMITTER, #2
 7. EMITTER, #1
 8. COLLECTOR, #1</p> |
| <p>STYLE 9:
 PIN 1. EMITTER, COMMON
 2. COLLECTOR, DIE #1
 3. COLLECTOR, DIE #2
 4. EMITTER, COMMON
 5. EMITTER, COMMON
 6. BASE, DIE #2
 7. BASE, DIE #1
 8. EMITTER, COMMON</p> | <p>STYLE 10:
 PIN 1. GROUND
 2. BIAS 1
 3. OUTPUT
 4. GROUND
 5. GROUND
 6. BIAS 2
 7. INPUT
 8. GROUND</p> | <p>STYLE 11:
 PIN 1. SOURCE 1
 2. GATE 1
 3. SOURCE 2
 4. GATE 2
 5. DRAIN 2
 6. DRAIN 2
 7. DRAIN 1
 8. DRAIN 1</p> | <p>STYLE 12:
 PIN 1. SOURCE
 2. SOURCE
 3. SOURCE
 4. GATE
 5. DRAIN
 6. DRAIN
 7. DRAIN
 8. DRAIN</p> |
| <p>STYLE 13:
 PIN 1. N.C.
 2. SOURCE
 3. SOURCE
 4. GATE
 5. DRAIN
 6. DRAIN
 7. DRAIN
 8. DRAIN</p> | <p>STYLE 14:
 PIN 1. N-SOURCE
 2. N-GATE
 3. P-SOURCE
 4. P-GATE
 5. P-DRAIN
 6. P-DRAIN
 7. N-DRAIN
 8. N-DRAIN</p> | <p>STYLE 15:
 PIN 1. ANODE 1
 2. ANODE 1
 3. ANODE 1
 4. ANODE 1
 5. CATHODE, COMMON
 6. CATHODE, COMMON
 7. CATHODE, COMMON
 8. CATHODE, COMMON</p> | <p>STYLE 16:
 PIN 1. EMITTER, DIE #1
 2. BASE, DIE #1
 3. EMITTER, DIE #2
 4. BASE, DIE #2
 5. COLLECTOR, DIE #2
 6. COLLECTOR, DIE #2
 7. COLLECTOR, DIE #1
 8. COLLECTOR, DIE #1</p> |
| <p>STYLE 17:
 PIN 1. VCC
 2. V2OUT
 3. V1OUT
 4. TXE
 5. RXE
 6. VEE
 7. GND
 8. ACC</p> | <p>STYLE 18:
 PIN 1. ANODE
 2. ANODE
 3. SOURCE
 4. GATE
 5. DRAIN
 6. DRAIN
 7. CATHODE
 8. CATHODE</p> | <p>STYLE 19:
 PIN 1. SOURCE 1
 2. GATE 1
 3. SOURCE 2
 4. GATE 2
 5. DRAIN 2
 6. MIRROR 2
 7. DRAIN 1
 8. MIRROR 1</p> | <p>STYLE 20:
 PIN 1. SOURCE (N)
 2. GATE (N)
 3. SOURCE (P)
 4. GATE (P)
 5. DRAIN
 6. DRAIN
 7. DRAIN
 8. DRAIN</p> |
| <p>STYLE 21:
 PIN 1. CATHODE 1
 2. CATHODE 2
 3. CATHODE 3
 4. CATHODE 4
 5. CATHODE 5
 6. COMMON ANODE
 7. COMMON ANODE
 8. CATHODE 6</p> | <p>STYLE 22:
 PIN 1. I/O LINE 1
 2. COMMON CATHODE/VCC
 3. COMMON CATHODE/VCC
 4. I/O LINE 3
 5. COMMON ANODE/GND
 6. I/O LINE 4
 7. I/O LINE 5
 8. COMMON ANODE/GND</p> | <p>STYLE 23:
 PIN 1. LINE 1 IN
 2. COMMON ANODE/GND
 3. COMMON ANODE/GND
 4. LINE 2 IN
 5. LINE 2 OUT
 6. COMMON ANODE/GND
 7. COMMON ANODE/GND
 8. LINE 1 OUT</p> | <p>STYLE 24:
 PIN 1. BASE
 2. EMITTER
 3. COLLECTOR/ANODE
 4. COLLECTOR/ANODE
 5. CATHODE
 6. CATHODE
 7. COLLECTOR/ANODE
 8. COLLECTOR/ANODE</p> |
| <p>STYLE 25:
 PIN 1. VIN
 2. N/C
 3. REXT
 4. GND
 5. IOUT
 6. IOUT
 7. IOUT
 8. IOUT</p> | <p>STYLE 26:
 PIN 1. GND
 2. dv/dt
 3. ENABLE
 4. ILIMIT
 5. SOURCE
 6. SOURCE
 7. SOURCE
 8. VCC</p> | <p>STYLE 27:
 PIN 1. ILIMIT
 2. OVLO
 3. UVLO
 4. INPUT+
 5. SOURCE
 6. SOURCE
 7. SOURCE
 8. DRAIN</p> | <p>STYLE 28:
 PIN 1. SW_TO_GND
 2. DASIC OFF
 3. DASIC_SW_DET
 4. GND
 5. V_MON
 6. VBULK
 7. VBULK
 8. VIN</p> |
| <p>STYLE 29:
 PIN 1. BASE, DIE #1
 2. EMITTER, #1
 3. BASE, #2
 4. EMITTER, #2
 5. COLLECTOR, #2
 6. COLLECTOR, #2
 7. COLLECTOR, #1
 8. COLLECTOR, #1</p> | <p>STYLE 30:
 PIN 1. DRAIN 1
 2. DRAIN 1
 3. GATE 2
 4. SOURCE 2
 5. SOURCE 1/DRAIN 2
 6. SOURCE 1/DRAIN 2
 7. SOURCE 1/DRAIN 2
 8. GATE 1</p> | | |

DOCUMENT NUMBER:	98ASB42564B	Electronic versions are uncontrolled except when accessed directly from the Document Repository. Printed versions are uncontrolled except when stamped "CONTROLLED COPY" in red.
DESCRIPTION:	SOIC-8 NB	PAGE 2 OF 2

ON Semiconductor and  are trademarks of Semiconductor Components Industries, LLC dba ON Semiconductor or its subsidiaries in the United States and/or other countries. ON Semiconductor reserves the right to make changes without further notice to any products herein. ON Semiconductor makes no warranty, representation or guarantee regarding the suitability of its products for any particular purpose, nor does ON Semiconductor assume any liability arising out of the application or use of any product or circuit, and specifically disclaims any and all liability, including without limitation special, consequential or incidental damages. ON Semiconductor does not convey any license under its patent rights nor the rights of others.

onsemi, **Onsemi**, and other names, marks, and brands are registered and/or common law trademarks of Semiconductor Components Industries, LLC dba "**onsemi**" or its affiliates and/or subsidiaries in the United States and/or other countries. **onsemi** owns the rights to a number of patents, trademarks, copyrights, trade secrets, and other intellectual property. A listing of **onsemi**'s product/patent coverage may be accessed at www.onsemi.com/site/pdf/Patent-Marking.pdf. **onsemi** reserves the right to make changes at any time to any products or information herein, without notice. The information herein is provided "as-is" and **onsemi** makes no warranty, representation or guarantee regarding the accuracy of the information, product features, availability, functionality, or suitability of its products for any particular purpose, nor does **onsemi** assume any liability arising out of the application or use of any product or circuit, and specifically disclaims any and all liability, including without limitation special, consequential or incidental damages. Buyer is responsible for its products and applications using **onsemi** products, including compliance with all laws, regulations and safety requirements or standards, regardless of any support or applications information provided by **onsemi**. "Typical" parameters which may be provided in **onsemi** data sheets and/or specifications can and do vary in different applications and actual performance may vary over time. All operating parameters, including "Typicals" must be validated for each customer application by customer's technical experts. **onsemi** does not convey any license under any of its intellectual property rights nor the rights of others. **onsemi** products are not designed, intended, or authorized for use as a critical component in life support systems or any FDA Class 3 medical devices or medical devices with a same or similar classification in a foreign jurisdiction or any devices intended for implantation in the human body. Should Buyer purchase or use **onsemi** products for any such unintended or unauthorized application, Buyer shall indemnify and hold **onsemi** and its officers, employees, subsidiaries, affiliates, and distributors harmless against all claims, costs, damages, and expenses, and reasonable attorney fees arising out of, directly or indirectly, any claim of personal injury or death associated with such unintended or unauthorized use, even if such claim alleges that **onsemi** was negligent regarding the design or manufacture of the part. **onsemi** is an Equal Opportunity/Affirmative Action Employer. This literature is subject to all applicable copyright laws and is not for resale in any manner.

PUBLICATION ORDERING INFORMATION

LITERATURE FULFILLMENT:

Email Requests to: orderlit@onsemi.com

onsemi Website: www.onsemi.com

TECHNICAL SUPPORT

North American Technical Support:
Voice Mail: 1 800-282-9855 Toll Free USA/Canada
Phone: 011 421 33 790 2910

Europe, Middle East and Africa Technical Support:

Phone: 00421 33 790 2910

For additional information, please contact your local Sales Representative

Mouser Electronics

Authorized Distributor

Click to View Pricing, Inventory, Delivery & Lifecycle Information:

[onsemi:](#)

[NCL30059BDR2G](#)